

BOTTOM VIEW

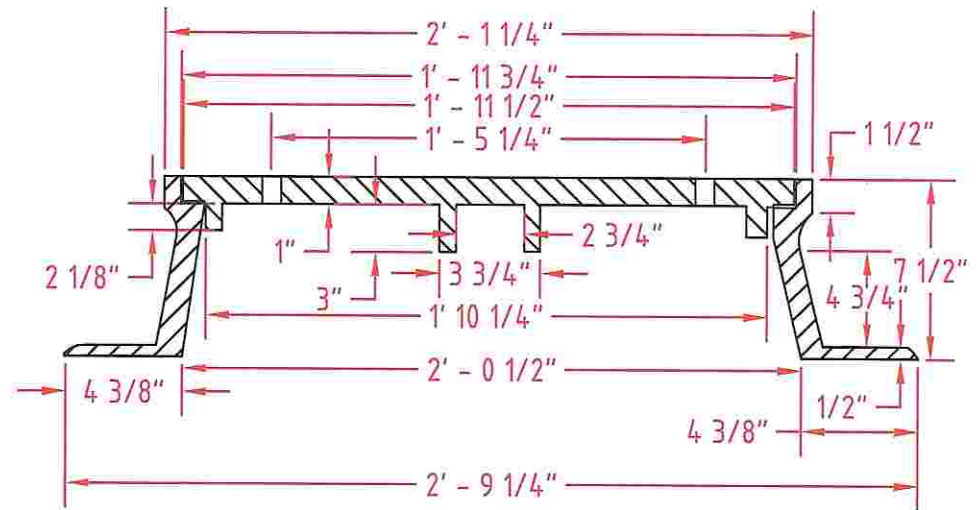

(U.S. FOUNDRY - 669, VULCAN - 1384 OR EQUAL)

NOTES:

1. ALL CASTINGS TO BE FREE FROM SAND HOLES. NO PLUGGING ALLOWED.
2. MACHINE ALL CONTACT SURFACES BETWEEN RING AND COVER.
3. PROVIDE TWO VENT HOLES IN COVER, 1" DIA. TAPERED TO 1-1/8" ON REVERSE SIDE.
4. MINIMUM WEIGHTS: COVER - 120 LBS. RING - 190 LBS.
5. ALL MANHOLE RINGS OUT OF ROAD RIGHT OF WAY SHALL BE BOLTED INTO MANHOLE WITH 5/8" DIAMETER KWIK BOLT STUD ANCHOR SYSTEM. HILTI BRAND OR APPROVED EQUAL.

UNION COUNTY PUBLIC WORKS DEPARTMENT
UNION COUNTY, N.C.

STANDARD DETAIL

RING & COVER

SCALE:
N.T.S.
DATE:
9-9-11

9